

>> ROTARY MAGNET

>> FEATURES:

- Magnetic protection without restricting powder flow
- 11,000 gauss plus rare earth cartridges with rotary action provides maximum separation efficiency
- Magnetic rotor is demountable from housing without tools
- Precision machined assembly for dust-tight operation
- Sanitary cube housing is self-draining ledge and crevice free
- Maintenance free direct drive, available in painted steel and stainless steel
- Customized welded inlet and outlet connections including BFM® fitting, Tri-clamp, flanged round or square

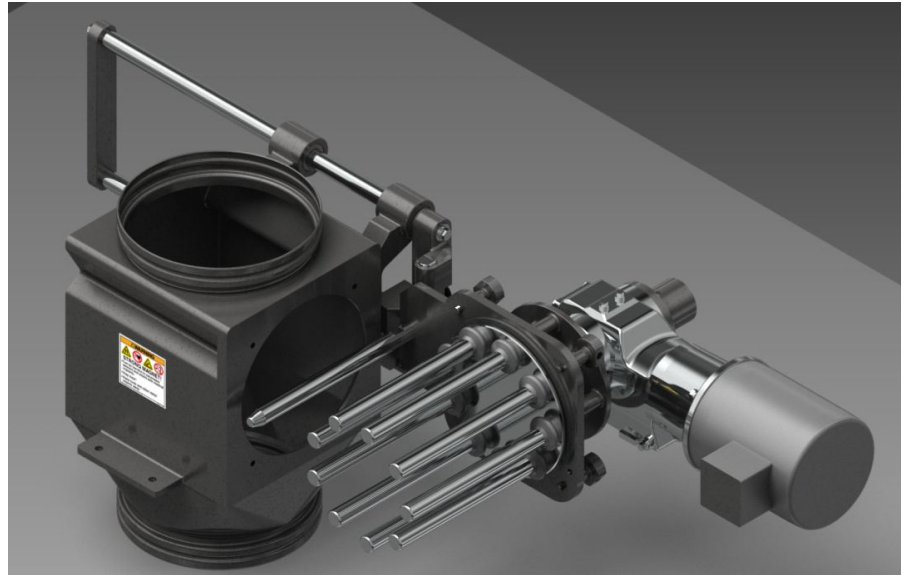

Rotary Magnet

Rotary magnets are designed to remove ferrous and weakly charged magnetic particles from product flows that tend to plug and bridge in stationary magnetic grates.

The unit rotates powerful magnetic tubes while the product passes through. The magnetic action attracts and retains the unwanted ferrous particles, and the rotary action prevents the product from packing the process stream.



Magnets are cleaned completely outside the product zone with wiper rings.

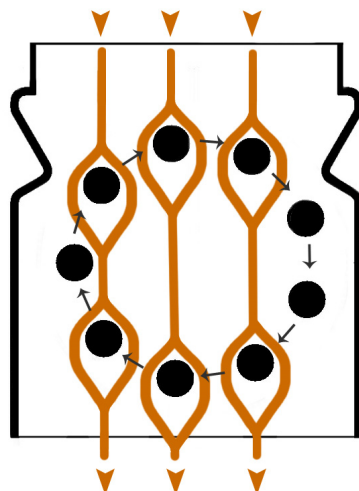

Cross-section view of Rotary Magnet.

The rotary action provides the highest product to magnet contact ratio for optimum separation efficiency, while also breaking apart soft lumps and cohesive materials.

Easy cleaning of the tubes is made possible by wiper rings, which are pulled off during the cleaning and particle removing process.



Powder Process-Solutions
Div. of Powder-Solutions Group
Ph: 877-933-2556
sales@powder-solutions.com
www.powder-solutions.com